

STOOL ASSEMBLY INSTRUCTIONS

Thank you for purchasing the Stool. Please read the instructions carefully to ensure safe operation of the product.

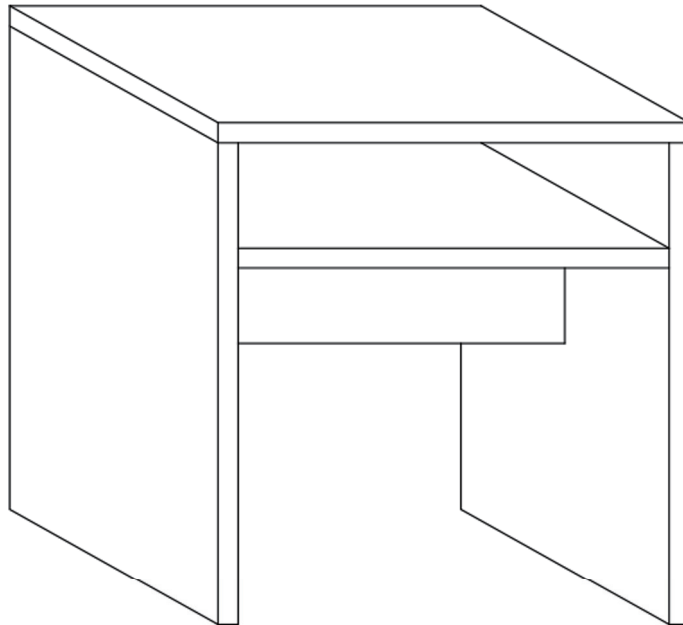

Size: 47x40x45.5cm

Colour: White/Grey

PLEASE READ this sheet prior to assembly to familiarise yourself with the various stages of construction.

Carefully open the pack supplied and check the contents against the parts and fittings check list. Do not destroy any of the packaging until you are certain that you have all the necessary parts for the assembly.

CAUTION: There are small components used in the construction of this unit. These loose items should be kept away from young children whilst assembling your unit to avoid the danger of choking hazards.

Tools Required

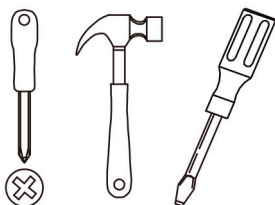

(NOT INCLUDED)



1 Person Build



30 MINS
Set Up

STOOL ASSEMBLY INSTRUCTIONS

IMPORTANT - READ CAREFULLY - RETAIN THESE INSTRUCTIONS FOR FUTURE REFERENCE.

INFORMATION

- This product is intended for a maximum load of 110 kgs. Do not exceed this weight.
- Due to the size of this product we recommend that it is assembled in the room intended for use.
- When you are ready to start, make sure that you have the right tools, plenty of space and a clean, dry area for assembly.
- Unwrap all packaging materials and place the components on top of the carton box or on a clean floor to prevent it from scratching.
- Check the pack and make sure you have all the parts listed.
- Ensure that this product is fully assembled as illustrated before use.
- Check all screws or bolts are tightened and inspect regularly.
- This product should only be used on firm, level ground.
- Tools are not included.

WARNINGS

- DO make sure the legs remain in contact with the ground.
- DO keep small parts out of reach of children.
- DO NOT use power tools to construct this product.
- DO NOT over tighten screws or bolts.
- DO NOT use this product if parts are missing, damaged or worn.
- DO NOT stand on this product

CARE INFORMATION

- Never use scourers, abrasives or chemical cleaners.
- To clean wipe with a sponge and warm soapy water. Do not use solvent based cleaners or detergents as they can bleach or damage the product

STOOL ASSEMBLY INSTRUCTIONS

Please check the pack contents before assembling this product. If any components are missing, please contact your retailer. The fittings pack contains small items that should be kept away from small children.

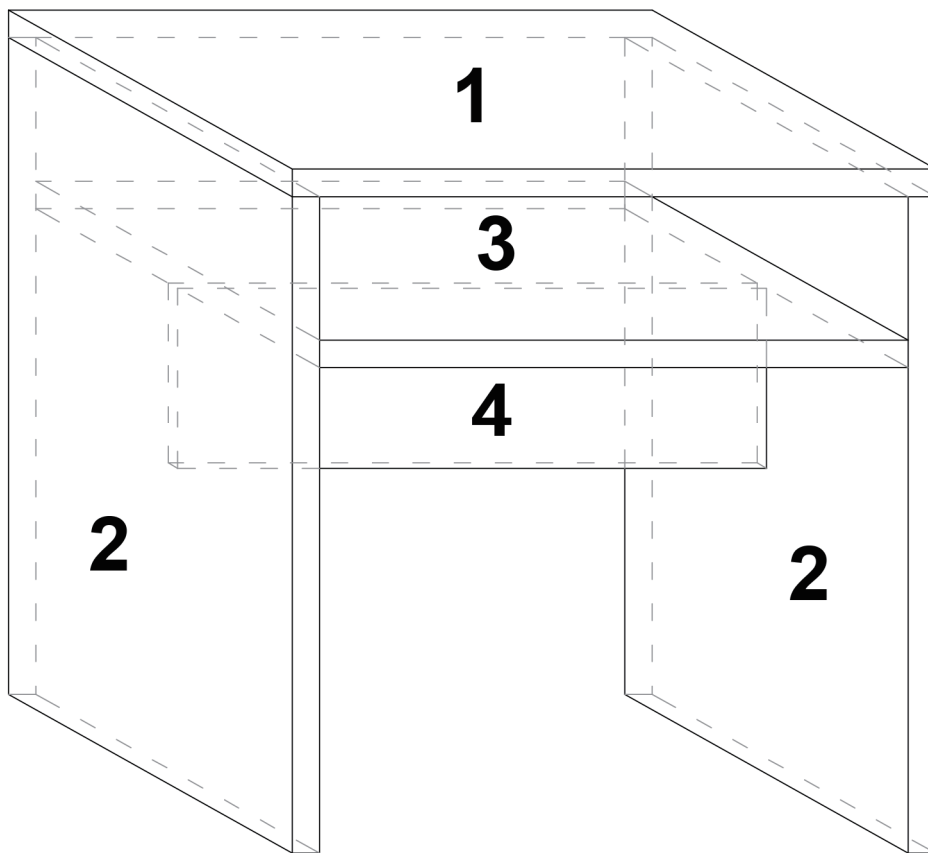

STOOL ASSEMBLY INSTRUCTIONS

PARTS

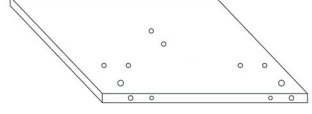
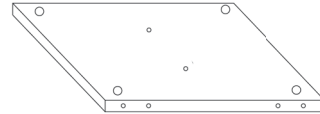
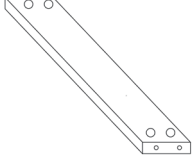
<p>1</p> 	<p>2</p> 
<p>DESCRIPTION: TOP PANEL QTY:1 PC DIMENSION: 470x400x15MM</p>	<p>DESCRIPTION: SIDE PANEL QTY:2 PCS DIMENSION: 400x390x15MM</p>
<p>3</p> 	<p>4</p> 
<p>DESCRIPTION: SHELF PANEL QTY:1 PC DIMENSION: 400x440x15MM</p>	<p>DESCRIPTION: SUPPORT PANEL QTY:1 PC DIMENSION: 440x100x15MM</p>

FIXINGS (TO SCALE)

Ref	Dimensions	Qty
A	CAM BOLT (6x35mm)	12
B	WOODEN DOWEL (6x30mm)	10
C	CAM LOCK (15x10mm)	12

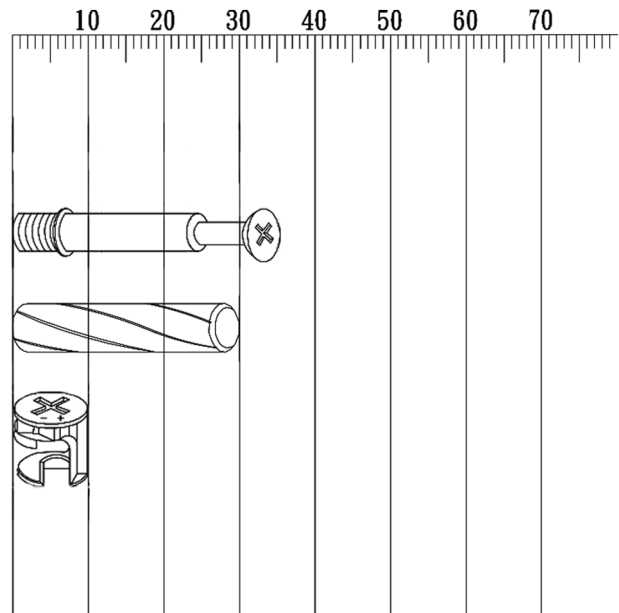

CAUTION: There are many small components used in the construction of this product. Please keep these components away from young children whilst assembling this product.

If you keep the fittings in a bowl during assembly you will be less likely to lose them!

STOOL ASSEMBLY INSTRUCTIONS

Layout Parts on Soft Surface

Layout all part on a soft surface i.e. Rug,carpet or packaging carton

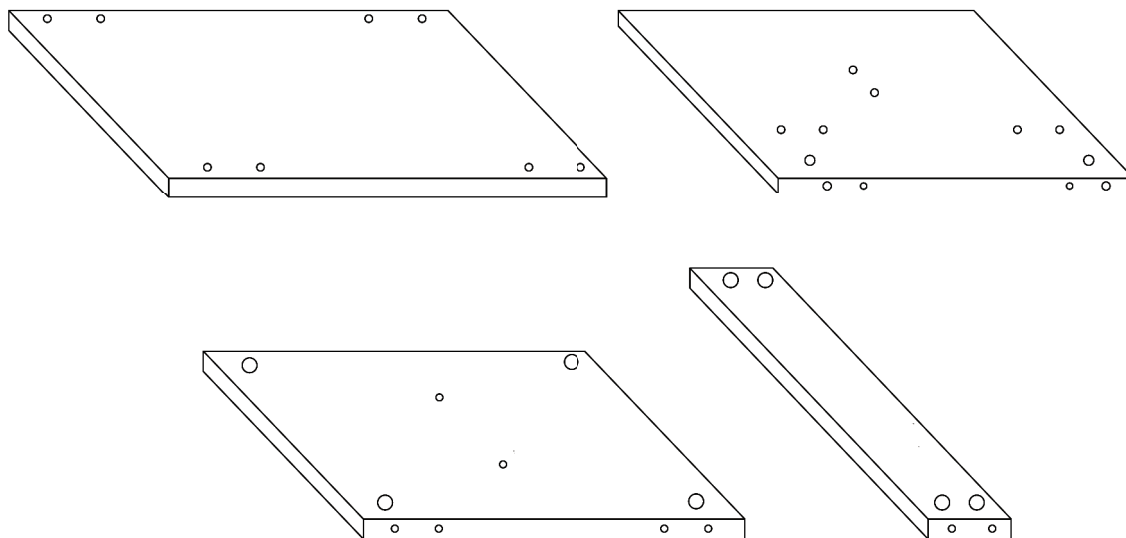

STOOL ASSEMBLY INSTRUCTIONS

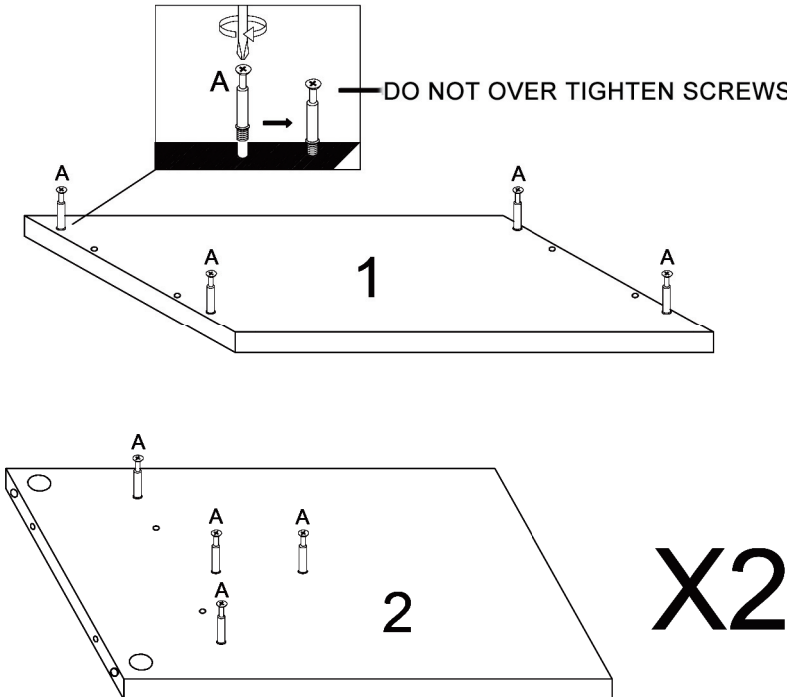
STEP 1	PARTS REQUIRED
 <p>DO NOT OVER TIGHTEN SCREWS</p> <p>1</p> <p>2</p> <p>X2</p>	<p>1: TOP PANEL X1</p> <p>2: SIDE PANEL X2</p> <p>A: CAM BOLT X12</p>

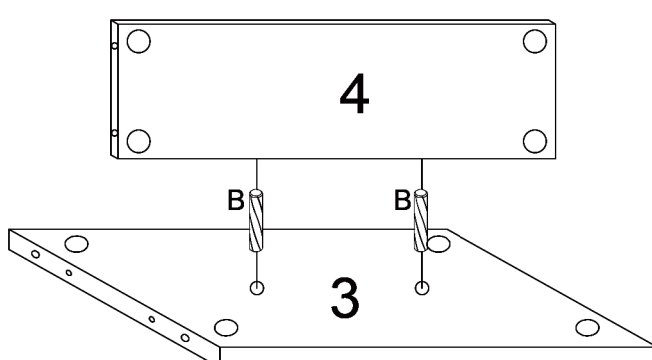
STEP 2	PARTS REQUIRED
 <p>3</p> <p>4</p> <p>B</p> <p>B</p>	<p>3: SHELF PANEL X1</p> <p>4: SUPPORT PANEL X1</p> <p>B: WOODEN DOWEL X2</p>

STOOL ASSEMBLY INSTRUCTIONS

STEP 3	PARTS REQUIRED
	<p>2: SIDE PANEL X1</p> <p>B: WOODEN DOWEL X2</p> <p>C: CAM LOCK X4</p>

STEP 4	PARTS REQUIRED
	<p>2: SIDE PANEL X1</p> <p>B: WOODEN DOWEL X2</p> <p>C: CAM LOCK X4</p>

STOOL ASSEMBLY INSTRUCTIONS

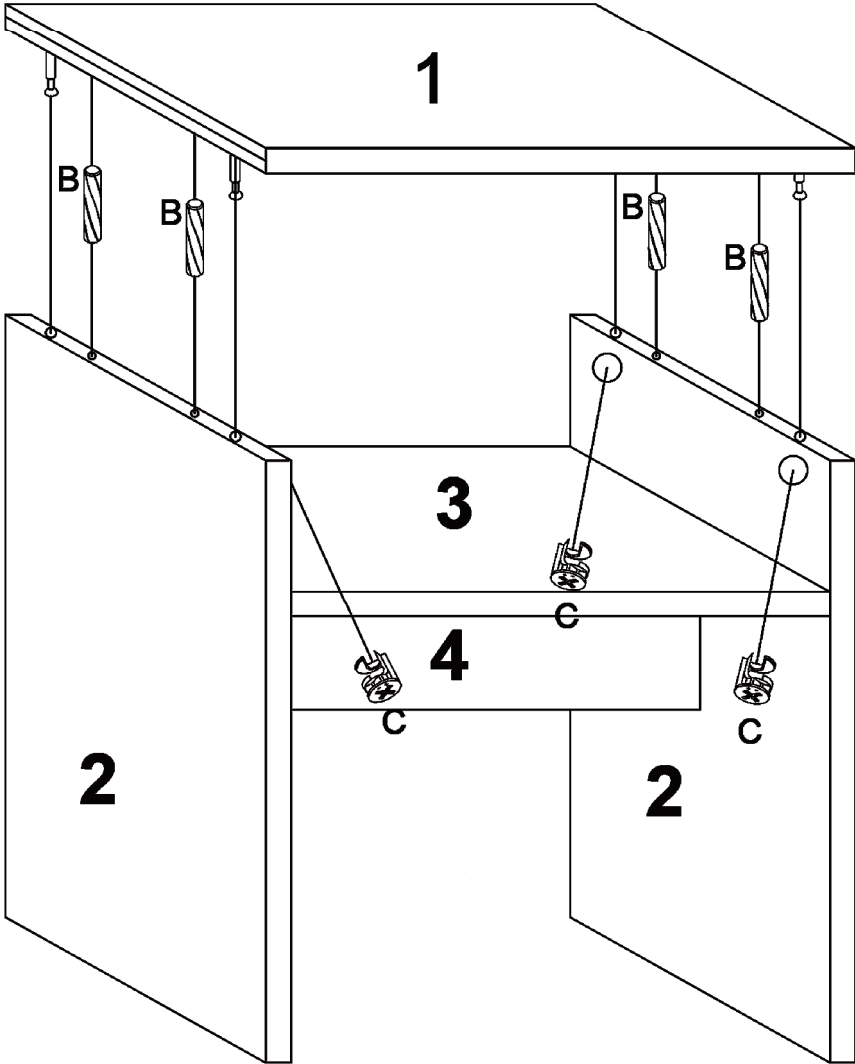
STEP 5	PARTS REQUIRED
 <p>The diagram illustrates the final assembly step. A top panel (1) is being attached to two side panels (2). Four wooden dowels (B) are used to secure the top panel to the side panels. Two cam locks (C) are used to secure the side panels to the base (4). The seat (3) is also shown in the diagram.</p>	<p>1: TOP PANEL X1</p> <p>B: WOODEN DOWEL X4</p> <p>C: CAM LOCK X4</p>

STOOL ASSEMBLY INSTRUCTIONS

Complete Assembly

Your **STOOL** is now completely assembled.

Periodically check to ensure that the components are in their proper position, free from damage.

Also, make sure the connectors are tight and secure.

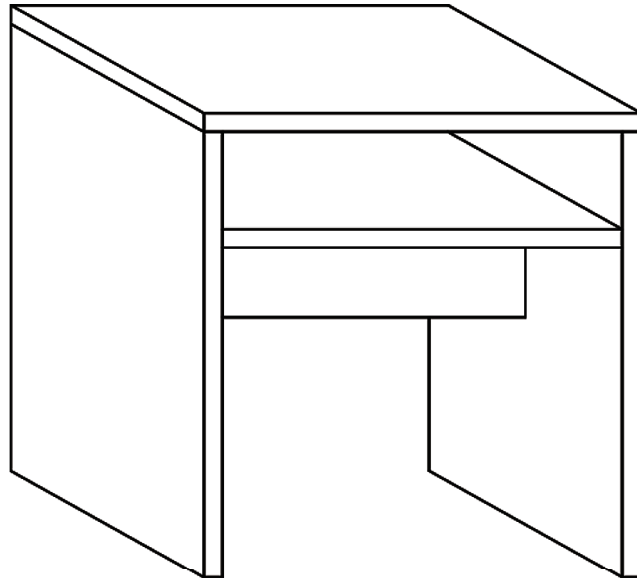

Retain these instructions for future reference.

